

Two X chromosomes
of a human female
Colored LM Magnification: 9500 \times

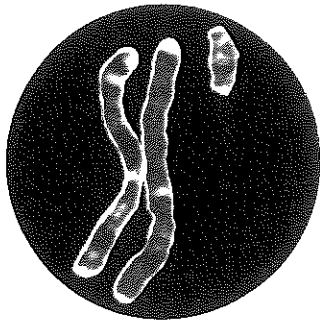
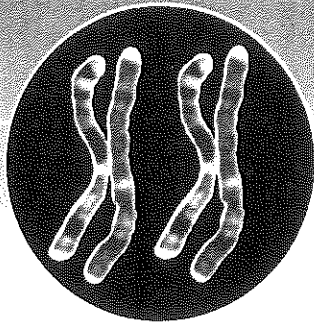

X and Y chromosomes
of a human male
Colored LM Magnification: 9500 \times

THEME FOCUS Cause and Effect
Complex forms of inheritance result in a wide diversity of characteristics.

BIG Idea Human inheritance does not always follow Mendel's laws.

Section 1 • Basic Patterns of Human Inheritance

Section 2 • Complex Patterns of Inheritance

Section 3 • Chromosomes and Human Heredity

Section 1

Reading Preview

Essential Questions

- How can genetic patterns be analyzed to determine dominant or recessive inheritance patterns?
- What are examples of dominant and recessive disorders?
- How can human pedigrees be constructed from genetic information?

Review Vocabulary

genes: segments of DNA that control the production of proteins

New Vocabulary

carrier
pedigree



Multilingual eGlossary

Basic Patterns of Human Inheritance

Key Idea The inheritance of a trait over several generations can be shown in a pedigree.

Real-World Reading Link Knowing a purebred dog's ancestry can help the owner know health problems that are common to that dog. Similarly, tracing human inheritance can show how a trait was passed down from one generation to the next.

Recessive Genetic Disorders

Connection to Biology Gregor Mendel's work was ignored for more than 30 years. During the early 1900s, scientists began to take an interest in heredity, and Mendel's work was rediscovered. About this time, Dr. Archibald Garrod, an English physician, became interested in a disorder linked to an enzyme deficiency called alkaptonuria (al kap tuh NYUR ee uh), which results in black urine. It is caused by acid excretion into the urine. Dr. Garrod observed that the condition appeared at birth and continued throughout the patient's life, ultimately affecting bones and joints. He also noted that alkaptonuria ran in families. With the help of another scientist, he determined that alkaptonuria was a recessive genetic disorder.

Today, progress continues to help us understand genetic disorders. Review **Table 1**, and recall that a recessive trait is expressed when the individual is homozygous recessive for that trait. Therefore, those with at least one dominant allele will not express the recessive trait. An individual who is heterozygous for a recessive disorder is called a **carrier**. Review **Table 2** as you read about several recessive genetic disorders.

Table 1

Review of Terms



Interactive Table



Term	Example	Definition
Homozygous	True-breeding yellow-seed pea plants would be YY, and green-seed pea plants would be yy. 	An organism with two of the same alleles for a particular trait is said to be homozygous for that trait.
Heterozygous	A plant that is Yy would be a yellow-seed pea. 	An organism with two different alleles for a particular trait is said to be heterozygous for that trait. When alleles are present in the heterozygous state, the dominant trait will be observed.

Table 2**Recessive Genetic Disorders in Humans**

Interactive Table

Disorder	Occurrence in the U.S.	Cause	Effect	Cure/Treatment
Cystic fibrosis	1 in 3500	The gene that codes for a membrane protein is defective.	<ul style="list-style-type: none"> • Excessive mucus production • Digestive and respiratory failure 	<ul style="list-style-type: none"> • No cure • Daily cleaning of mucus from the lungs • Mucus-thinning drugs • Pancreatic enzyme supplements
Albinism	1 in 17,000	Genes do not produce normal amounts of the pigment melanin.	<ul style="list-style-type: none"> • No color in the skin, eyes and hair • Skin susceptible to UV damage • Vision problems 	<ul style="list-style-type: none"> • No cure • Protect skin from the Sun and other environmental factors • Visual rehabilitation
Galactosemia	1 in 50,000 to 70,000	Absence of the gene that codes for the enzyme that breaks down galactose	<ul style="list-style-type: none"> • Mental disabilities • Enlarged liver • Kidney failure 	<ul style="list-style-type: none"> • No cure • Restriction of lactose/galactose in the diet
Tay-Sachs disease	1 in 2500 (affects people of Jewish descent)	Absence of a necessary enzyme that breaks down fatty substances	<ul style="list-style-type: none"> • Buildup of fatty deposits in the brain • Mental disabilities 	<ul style="list-style-type: none"> • No cure or treatment • Death by age 5

Cystic fibrosis One of the most common recessive genetic disorders among Caucasians is cystic fibrosis, which affects the mucus-producing glands, digestive enzymes, and sweat glands. Chloride ions are not properly transported out of the cells of a person with cystic fibrosis. Because of the high concentration of chloride ions in cells, water does not diffuse from cells. This causes a secretion of thick mucus that affects many areas of the body. The thick mucus clogs the ducts in the pancreas, interrupts digestion, and blocks the tiny respiratory pathways in the lungs. Patients with cystic fibrosis are at a higher risk of infection because of excess mucus in their lungs.

Treatment for cystic fibrosis currently includes physical therapy, medication, special diets, and the use of replacement digestive enzymes. Genetic tests are available to determine whether a person is a carrier, indicating they are carrying the recessive gene.

Albinism In humans, albinism is caused by altered genes, resulting in the absence of the skin pigment melanin in hair and eyes. Albinism is found in other animals as well. A person with albinism has white hair, very pale skin, and pink pupils. The absence of pigment in eyes can cause problems with vision. Although we all must protect our skin from the Sun's ultraviolet radiation, those with albinism need to be especially careful.

Tay-Sachs disease Tay-Sachs (TAY saks) disease is a recessive genetic disorder. Its gene is found on chromosome 15. Often identified by a cherry-red spot on the back of the eye, Tay-Sachs disease (TSD) seems to be predominant among Jews of eastern European descent.

FOLDABLES

Incorporate information from this section into your Foldable.



VOCABULARY

ACADEMIC VOCABULARY

Decline

to gradually waste away; or a downward slope

His health declined because of the disease.

TSD is caused by the absence of the enzymes responsible for breaking down fatty acids called gangliosides. Normally, gangliosides are made and then dissolved as the brain develops. However, in a person affected by Tay-Sachs disease, the gangliosides accumulate in the brain, inflating brain nerve cells and causing mental deterioration.

Galactosemia Galactosemia (guh lak tuh SEE mee uh) is characterized by the inability of the body to digest galactose. During digestion, lactose from milk breaks down into galactose and glucose. Glucose is the sugar used by the body for energy and circulates in the blood. Galactose must be broken down into glucose by an enzyme named GALT. Persons who lack or have defective GALT cannot digest galactose. Persons with galactosemia should avoid milk products.

Dominant Genetic Disorders

Not all genetic disorders are caused by recessive inheritance. As described in **Table 3**, some disorders, such as the rare disorder Huntington's disease, are caused by dominant alleles. That means those who do not have the disorder are homozygous recessive for the trait.

Huntington's disease The dominant genetic disorder Huntington's disease affects the nervous system and occurs in one out of 10,000 people in the U.S. The symptoms of this disorder first appear in affected individuals between the ages of 30 and 50 years old. The symptoms include a gradual loss of brain function, uncontrollable movements, and emotional disturbances. Genetic tests are available to detect this dominant allele. However, no preventive treatment or cure for this disease exists.

Achondroplasia An individual with achondroplasia (a kahn droh PLAY zhee uh) has a small body size and limbs that are comparatively short. Achondroplasia is the most common form of dwarfism. A person with achondroplasia will have an adult height of about four feet and will have a normal life expectancy.

Interestingly, 75 percent of individuals with achondroplasia are born to parents of average size. When children with achondroplasia are born to parents of average size, the conclusion is that the condition occurred because of a new mutation or a genetic change.

 **Reading Check Compare** the chances of inheriting a dominant disorder to the chances of inheriting a recessive disorder if you have one parent with the disease.

Table 3

Dominant Genetic Disorders in Humans



Interactive Table

Disorder	Occurrence in the U.S.	Cause	Effect	Cure/Treatment
Huntington's disease	1 in 10,000	A gene affecting neurological function is defective.	<ul style="list-style-type: none"> • Decline of mental and neurological functions • Ability to move deteriorates 	<ul style="list-style-type: none"> • No cure or treatment
Achondroplasia	1 in 25,000	A gene that affects bone growth is abnormal.	<ul style="list-style-type: none"> • Short arms and legs • Large head 	<ul style="list-style-type: none"> • No cure or treatment

Key to Symbols

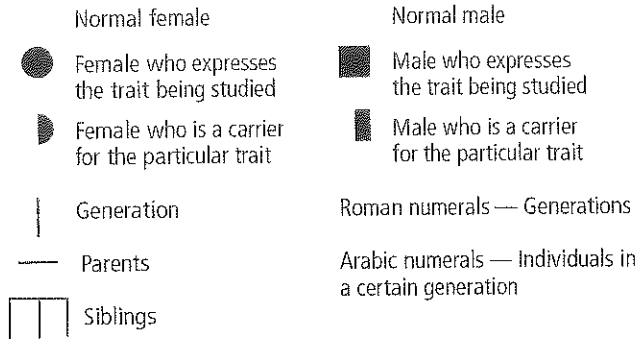

Example Pedigree

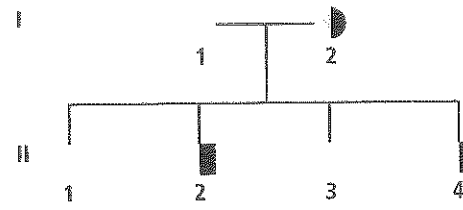

• **Figure 1** A pedigree uses standard symbols to indicate what is known about the trait being studied.



Personal Tutor

Pedigrees

In organisms such as peas and fruit flies, scientists can perform crosses to study genetic relationships. In the case of humans, a scientist studies a family history using a **pedigree**, a diagram that traces the inheritance of a particular trait through several generations. A pedigree uses symbols to illustrate inheritance of the trait. Males are represented by squares, and females are represented by circles, as shown in **Figure 1**. One who expresses the trait being studied is represented by a dark, or filled, square or circle, depending on their gender. One who does not express the trait is represented by an unfilled square or circle.

A horizontal line between two symbols shows that these individuals are the parents of the offspring listed below them. Offspring are listed in descending birth order from left to right and are connected to each other and their parents.

A pedigree uses a numbering system in which Roman numerals represent generations, and individuals are numbered by birth order using Arabic numbers. For example, in **Figure 1**, individual III is a female who is the firstborn in generation II.

Analyzing Pedigrees

A pedigree illustrating Tay-Sachs disease is shown in **Figure 2**. Recall from **Table 2** that Tay-Sachs disease is a recessive genetic disorder caused by the lack of an enzyme involved in lipid metabolism. The missing enzyme causes lipids to build up in the central nervous system, which can lead to death.

Examine the pedigree in **Figure 2**. Note that two unaffected parents, I1 and I2, have an affected child—II3, indicating that each parent has one recessive allele—they both are heterozygous and carriers for the trait. The half-filled square and circle show that both parents are carriers.

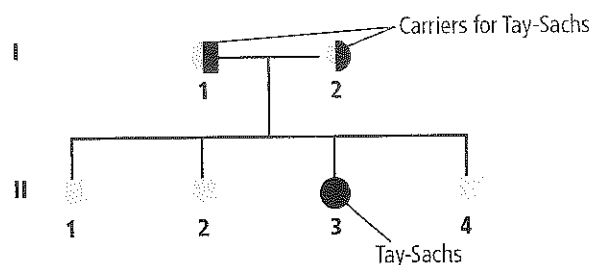

• **Figure 2** This pedigree illustrates the inheritance of the recessive disorder Tay-Sachs disease. Note that two unaffected parents (I1 and I2) can have an affected child (II3).



• **Figure 3** This pedigree illustrates the inheritance of a dominant disorder. Note that affected parents can pass on their genes (II2, II5), but unaffected parents cannot have an affected child (III2).

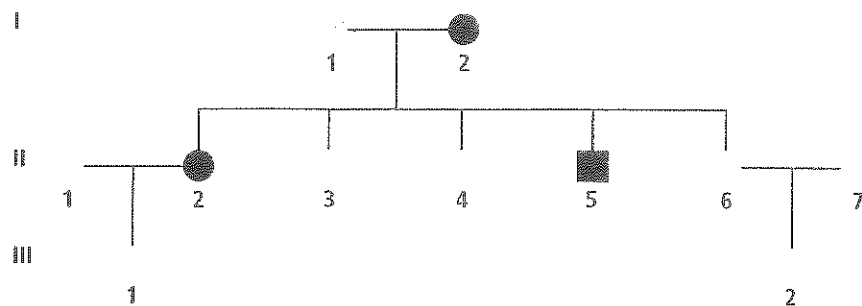

The pedigree in **Figure 3** shows the inheritance of the dominant genetic disorder polydactyly (pah lee DAK tuh lee). People with this disorder have extra fingers and toes. Recall that with dominant inheritance the trait is expressed when at least one dominant allele is present. An individual with an unaffected parent and a parent with polydactyly could be either heterozygous or homozygous recessive for the trait. Each unaffected person would be homozygous recessive for the trait.

For example, in **Figure 3**, individual I2 has polydactyly, indicated by the dark circle. Because she shows the trait, she is either homozygous dominant or heterozygous. It can be inferred that she is heterozygous—having one dominant gene and one recessive gene—because offspring II3 and II4 do not have the disorder. Notice that II6 and II7, two unaffected parents, have an unaffected offspring—III2. What can be inferred about II2, based on the phenotype of her parents and her offspring?

MiniLab 1

Investigate Human Pedigrees



Where are the branches on the family tree? Unlike some organisms, humans reproduce slowly and produce few offspring at one time. One method used to study human traits is pedigree analysis.

Procedure

1. Read and complete the lab safety form.
2. Imagine that you are a geneticist interviewing a person about his or her family concerning the hypothetical trait of hairy earlobes.
3. From the transcript below, construct a pedigree. Use appropriate symbols and format.

"My name is Scott. My great grandfather Walter had hairy earlobes (HEs), but great grandma Elsie did not. Walter and Elsie had three children: Lola, Leo, and Duane. Leo, the oldest, has HEs, as does the middle child, Lola; but the youngest child, Duane, does not. Duane never married and has no children. Leo married Bertie, and they have one daughter, Patty. In Leo's family, he is the only one with HEs. Lola married John, and they have two children: Carolina and Luetta. John does not have HEs, but both of his daughters do."

Analysis

1. **Assess** In what ways do pedigrees simplify the analysis of inheritance?
2. **Think Critically** Using this lab as a frame of reference, how can we put to practical use our understanding of constructing and analyzing human pedigrees?

Inferring genotypes Pedigrees are used to infer genotypes from the observation of phenotypes. By knowing physical traits, genealogists can determine what genes an individual is most likely to have. Phenotypes of entire families are analyzed in order to determine family genotypes, as symbolized in **Figure 3**.

Pedigrees help genetic counselors determine whether inheritance patterns are dominant or recessive. Once the inheritance pattern is determined, the genotypes of the individuals can largely be resolved through pedigree analysis. To analyze pedigrees, one particular trait is studied, and a determination is made as to whether that trait is dominant or recessive. Dominant traits are easier to recognize than recessive traits because dominant traits are exhibited in the phenotype.

A recessive trait will not be expressed unless the person is homozygous recessive for the trait. That means that a recessive allele is passed on by each parent. When recessive traits are expressed, the ancestry of the person expressing the trait is followed for several generations to determine which parents and grandparents were carriers of the recessive allele.

Predicting disorders If good records have been kept within families, disorders in future offspring can be predicted. However, more accuracy can be expected if several individuals within the family can be evaluated. The study of human genetics is difficult, because scientists are limited by time, ethics, and circumstances. For example, it takes decades for each generation to mature and then to have offspring when the study involves humans. Therefore, good record keeping, where it exists, helps scientists use pedigree analysis to study inheritance patterns, to determine phenotypes, and to ascertain genotypes within a family.

CAREERS IN BIOLOGY

Genealogist A genealogist studies or traces the descent of individuals or families. Many professional genealogists are board-certified and accredited.

Section 1 Assessment

Section Summary

- Genetic disorders can be caused by dominant or recessive alleles.
- Cystic fibrosis is a genetic disorder that affects mucus and sweat secretions.
- Individuals with albinism do not have melanin in their skin, hair, and eyes.
- Huntington's disease affects the nervous system.
- Achondroplasia sometimes is called dwarfism.
- Pedigrees are used to study human inheritance patterns.

Understand Main Ideas

1. **Construct** a family pedigree of two unaffected parents with a child who suffers from cystic fibrosis.
2. **Explain** the type of inheritance associated with Huntington's disease and achondroplasia.
3. **Interpret** Can two parents with albinism have an unaffected child? Explain.
4. **Diagram** Suppose both parents can roll their tongues but their son cannot. Draw a pedigree showing this trait, and label each symbol with the appropriate genotype.

Think Critically

MATH in Biology

5. Phenylketonuria (PKU) is a recessive genetic disorder. If both parents are carriers, what is the probability of this couple having a child with PKU? What is the chance of this couple having two children with PKU?
6. **Determine** When a couple requests a test for the cystic fibrosis gene, what types of questions might the physician ask before ordering the tests?



Section 2

Reading Preview

Essential Questions

- What are the differences between various complex inheritance patterns?
- How can sex-linked inheritance patterns be analyzed?
- How can the environment influence the phenotype of an organism?

Review Vocabulary

gamete: a mature sex cell (sperm or egg) with a haploid number of chromosomes

New Vocabulary

incomplete dominance
codominance
multiple alleles
epistasis
sex chromosome
autosome
sex-linked trait
polygenic trait



Multilingual eGlossary

Complex Patterns of Inheritance

Key Idea Complex inheritance of traits does not follow inheritance patterns described by Mendel.

Real-World Reading Link Imagine that you have red-green color blindness. In bright light, red lights do not stand out against surroundings. At night, green lights look like white streetlights. To help those with red-green color blindness, traffic lights always follow the same pattern. Red-green color blindness, however, does not follow the same pattern of inheritance described by Mendel.

Incomplete Dominance

Recall that when an organism is heterozygous for a trait, its phenotype will be that of the dominant trait. For example, if the genotype of a pea plant is Tt and T is the genotype for the dominant trait *tall*, then its phenotype will be tall. When red-flowered snapdragons ($C^R C^R$) are crossed with white-flowered snapdragons ($C^W C^W$), the heterozygous offspring have pink flowers ($C^R C^W$), as shown in **Figure 4**. This is an example of **incomplete dominance**, in which the heterozygous phenotype is an intermediate phenotype between the two homozygous phenotypes. When the heterozygous F_1 generation snapdragon plants are allowed to self-fertilize, as in **Figure 4**, the flowers are red, pink, and white in a 1:2:1 ratio, respectively.

Codominance

Recall that when an organism is heterozygous for a particular trait, the dominant phenotype is expressed. In a complex inheritance pattern called **codominance**, both alleles are expressed in the heterozygous condition. Sickle-cell disease provides a case study of codominant inheritance.



Personal Tutor

● **Figure 4** The color of snapdragon flowers is a result of incomplete dominance. When a plant with white flowers is crossed with a plant with red flowers, the offspring have pink flowers. Red, pink, and white offspring will result from self-fertilization of a plant with pink flowers.

Predict what would happen if you crossed a pink flower with a white flower.

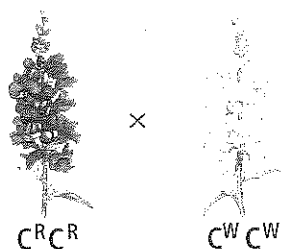

Self-fertilization

	C^R	C^W
C^R	$C^R C^R$	$C^R C^W$
C^W	$C^R C^W$	$C^W C^W$

Phenotype ratio 1:2:1

Color-Enhanced SEM Magnification: 10,000×

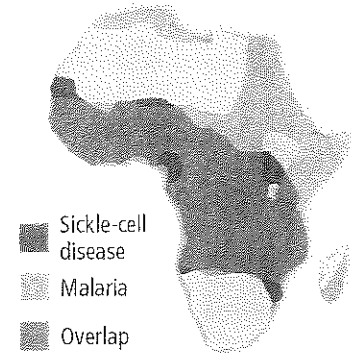
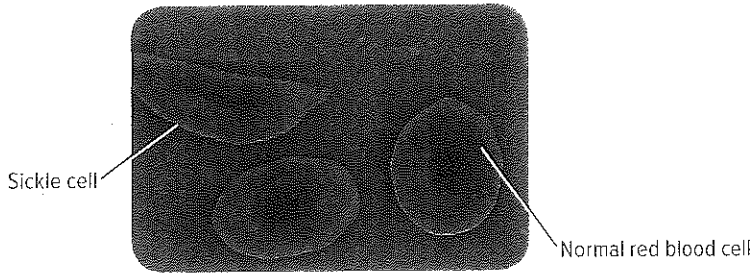

Figure 5

Left: Normal red blood cells are flat and disk-shaped. Sickle-shaped cells are elongated and C-shaped. They can clump, blocking circulation in small vessels.

Right: The sickle-cell allele increases resistance to malaria.

Sickle-cell disease The allele responsible for sickle-cell disease is particularly common in people of African descent, with about nine percent of African Americans having one form of the trait. Sickle-cell disease affects red blood cells and their ability to transport oxygen. The photograph in **Figure 5** shows the blood cells of an individual who is heterozygous for the sickle-cell trait. Changes in hemoglobin—the protein in red blood cells—cause those blood cells to change to a sickle, or C-shape. Sickle-shaped cells do not effectively transport oxygen because they block circulation in small blood vessels. Those who are heterozygous for the trait have both normal and sickle-shaped cells. These individuals can lead relatively normal lives, as the normal blood cells compensate for the sickle-shaped cells.

Sickle-cell disease and malaria Note in **Figure 5** the distribution of both sickle-cell disease and malaria in Africa. Some areas with sickle-cell disease overlap areas of widespread malaria. Why might such high levels of the sickle-cell allele exist in central Africa? Scientists have discovered that those who are heterozygous for the sickle-cell trait also have a higher resistance to malaria. The death rate due to malaria is lower where the sickle-cell trait is higher. Because less malaria exists in those areas, more people live to pass on the sickle-cell trait to offspring. Consequently, sickle-cell disease continues to increase in Africa.

DATA ANALYSIS LAB 1

Based on Real Data*

Interpret the Graph

What is the relationship between sickle-cell disease and other complications? Patients who have been diagnosed with sickle-cell disease face many symptoms, including respiratory failure and neurological problems. The graph shows the relationship between age and two different symptoms—pain and fever—during the two weeks preceding an episode of acute chest syndrome and hospitalization.

Think Critically

- 1. State** which age group has the highest level of pain before being hospitalized.
- 2. Describe** the relationship between age and fever before hospitalization.

Data and Observations

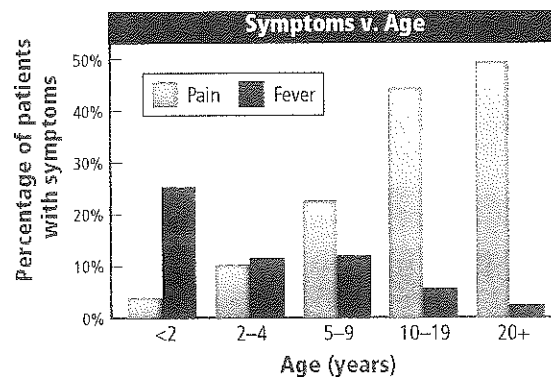

*Data obtained from: Walters, et al. 2002. Novel therapeutic approaches in sickle cell disease. *Hematology* 17: 10-34.



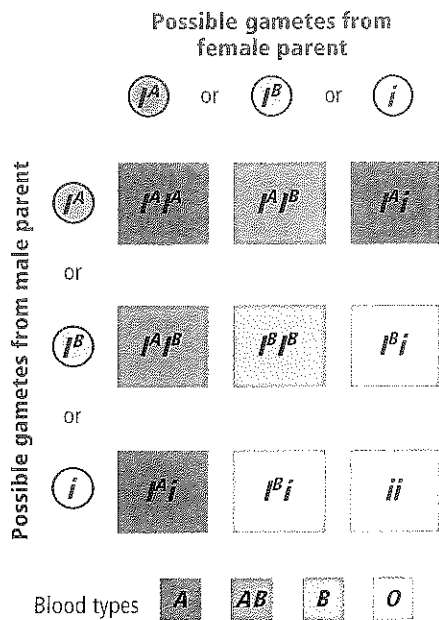

* **Figure 6** There are three forms of alleles in the ABO blood group— I^A , I^B , and i .

* **Figure 7** Rabbits have multiple alleles for coat color. The four alleles provide four basic variations in coat color.

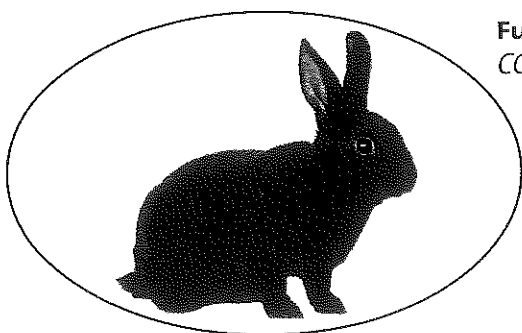

Full color
 CC or Cc or Cc^h or Cc^h

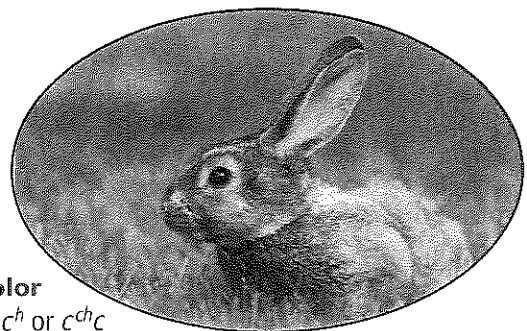

Not full color
 $c^h c^h$ or $c^h c^h$ or $c^h c$

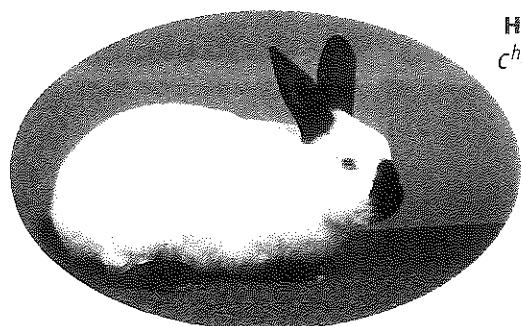

Himalayan
 $c^h c^h$ or $c^h c$

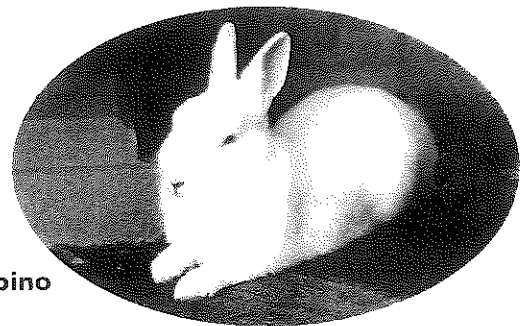

Albino
 cc

Multiple Alleles

Not all traits are determined by two alleles. Some forms of inheritance are determined by more than two alleles referred to as **multiple alleles**. An example of such a trait is human blood group.

Blood groups in humans The ABO blood group, shown in **Figure 6**, has three forms of alleles, sometimes called AB markers: I^A is blood type A; I^B is blood type B; and i is blood type O. Type O is the absence of AB markers. Note that allele i is recessive to I^A and I^B . However, I^A and I^B are codominant; blood type AB results from both I^A and I^B alleles. Therefore, the ABO blood group is an example of both multiple alleles and codominance.

The Rh blood group includes Rh factors, inherited from each parent. Rh factors are either positive or negative (Rh+ or Rh-); Rh+ is dominant. The Rh factor is a blood protein named after the rhesus monkey because studies of the rhesus monkey led to discovery of that blood protein.

Coat color of rabbits Multiple alleles can demonstrate a hierarchy of dominance. In rabbits, four alleles code for coat color: C , c^h , c^h , and c . Allele C is dominant to the other alleles and results in a full color coat. Allele c is recessive and results in an albino phenotype when the genotype is homozygous recessive. Allele c^h is dominant to c , and allele c^h is dominant to c and the hierarchy of dominance can be written as $C > c^h > c^h > c$. **Figure 7** shows the genotypes and phenotypes possible for rabbit-coat color. Full color is dominant over not full color, which is dominant over Himalayan, which is dominant over albino.

The presence of multiple alleles increases the possible number of genotypes and phenotypes. Without multiple-allele dominance, two alleles, such as T and t , produce only three possible genotypes—in this example TT , Tt , and tt —and two possible phenotypes. However, the four alleles for rabbit-coat color produce ten possible genotypes and four phenotypes, as shown in **Figure 7**. More variation in rabbit coat color comes from the interaction of the color gene with other genes.



$eebb$



$eeB_$



E_bb



$E_B_$

No dark pigment present in fur

Dark pigment present in fur

Epistasis

Coat color in Labrador retrievers can vary from yellow to black. This variety is the result of one allele hiding the effects of another allele, an interaction called **epistasis** (ih PIHS tuh sus). A Labrador's coat color is controlled by two sets of alleles. The dominant allele E determines whether the fur will have dark pigment. The fur of a dog with genotype ee will not have any pigment. The dominant B allele determines how dark the pigment will be. Study **Figure 8**. If the dog's genotype is $EEbb$ or $Eebb$, the dog's fur will be chocolate brown. Genotypes $eebb$, $eeBb$, and $eeBB$ will produce a yellow coat, because the e allele masks the effects of the dominant B allele.

Sex Determination

Each cell in your body, except for gametes, contains 46 chromosomes, or 23 pairs of chromosomes. One pair of these chromosomes, the **sex chromosomes**, determines an individual's gender. There are two types of sex chromosomes—X and Y. Individuals with two X chromosomes are female, and individuals with an X and a Y chromosome are male. The other 22 pairs of chromosomes are called **autosomes**. The offspring's gender is determined by the combination of sex chromosomes in the egg and sperm cell, as shown in **Figure 9**.

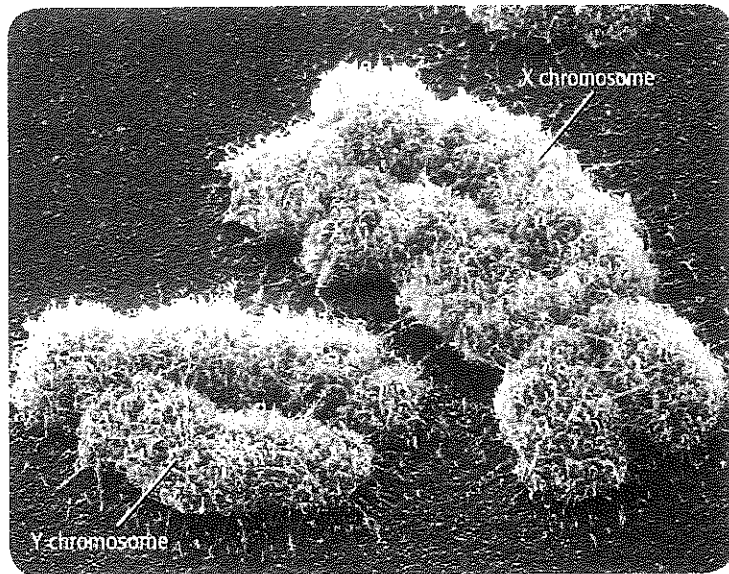

• **Figure 8** The results of epistasis in coat color in Labrador retrievers show an interaction of two genes, each with two alleles. Note that an underscore in the genotype allows for either a dominant or recessive gene.

• **Figure 9**
Left: The size and shape of the Y chromosome and the X chromosome are quite different from one another.
Right: The segregation of the sex chromosomes into gametes and the random combination of sperm and egg cells result in an approximately 1:1 ratio of males to females.

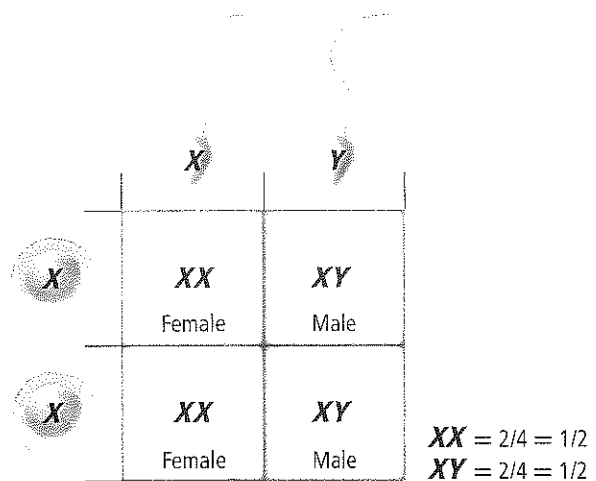

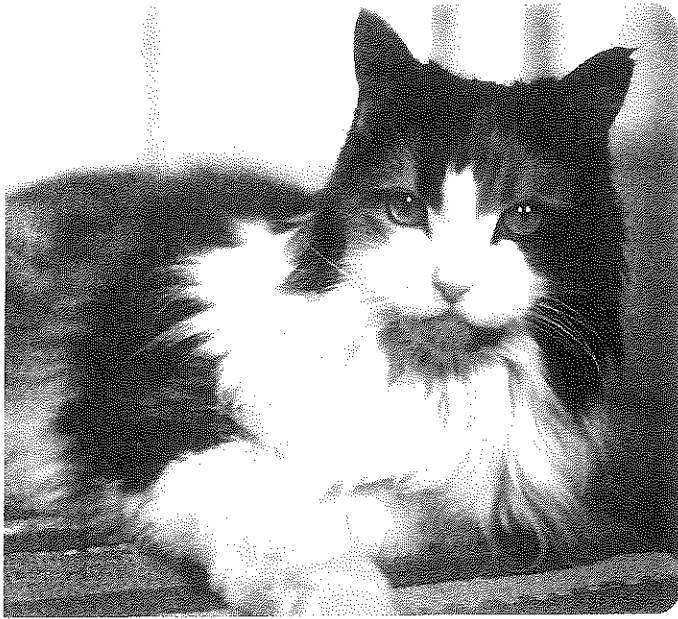
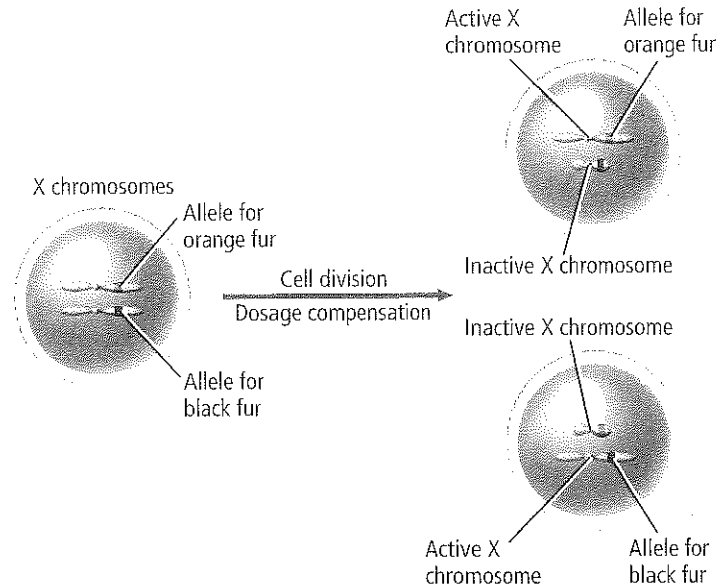

Figure 10 The calico coat of this cat results from the random inactivation of the X chromosomes in body cells. One X chromosome codes for orange fur, and one X chromosome codes for black fur, as illustrated on the right.



Dosage Compensation

Human females have 22 pairs of autosomes and one pair of X chromosomes. Males have 22 pairs of autosomes, along with one X and one Y chromosome. If you examine the X and Y chromosomes in **Figure 9**, you will notice that the X chromosome is larger than the Y chromosome. The X chromosome carries a variety of genes that are necessary for the development of both females and males. The Y chromosome mainly has genes that relate to the development of male characteristics.

Because females have two X chromosomes, it seems as though females get two doses of the X chromosome and males get only one dose. To balance the difference in the dose of X-related genes, one of the X chromosomes stops working in each of the female's body cells. This often is called dosage compensation or X-inactivation. Which X chromosome stops working in each body cell is a completely random event. Dosage compensation occurs in all mammals.

As a result of the Human Genome Project, the National Institutes of Health (NIH) has released new information on the sequence of the human X chromosome. Researchers now think that some genes on the inactivated X chromosome are more active than was previously thought.

Chromosome inactivation The coat colors of the calico cat shown in **Figure 10** are caused by the random inactivation of a particular X chromosome. The resulting colors depend on the X chromosome that is activated. The orange patches are formed by the inactivation of the X chromosome carrying the allele for black coat color. Similarly, the black patches are a result of the inactivation of the X chromosome carrying the allele for orange coat color.

Barr bodies The inactivated X chromosomes can be observed in cells. In 1949, Canadian scientist Murray Barr observed inactivated X chromosomes in female calico cats. He noticed a condensed, darkly stained structure in the nucleus. The darkly stained, inactivated X chromosomes, such as the one shown in **Figure 11**, are called Barr bodies. It was discovered later that only females, including human females, have Barr bodies in their cell nuclei.

Figure 11 An inactivated X chromosome in a female body cell is called a Barr body, a dark body usually found near the nucleus.

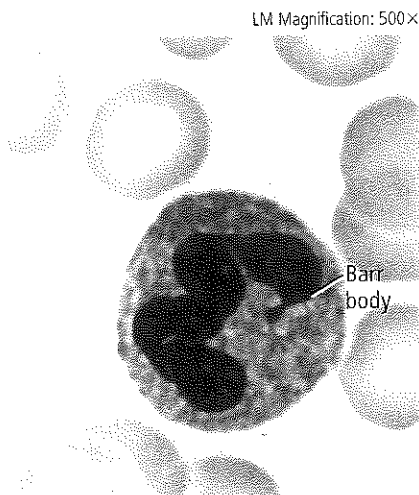

Sex-Linked Traits

Traits controlled by genes located on the X chromosome are called **sex-linked traits**, or X-linked traits. Because males have only one X chromosome, they are affected by recessive X-linked traits more often than are females. Females are less likely to express a recessive X-linked trait because the other X chromosome may mask the effect of the trait.

Some traits that are located on autosomes may appear to be sex-linked, even though they are not. This occurs when an allele appears to be dominant in one gender but recessive in the other. For example, the allele for baldness is recessive in females but dominant in males, causing hair loss that follows a typical pattern called male-pattern baldness. A male would be bald if he were heterozygous for the trait, while a female would be bald only if she were homozygous recessive.

Red-green color blindness The trait for red-green color blindness is a recessive X-linked trait. About 8 percent of males in the United States have red-green color blindness. The photos in **Figure 12** show how a person with red-green color blindness might view colors compared to a person who does not have red-green color blindness.

Study the Punnett square shown in **Figure 12**. The mother is a carrier for color blindness because she has the recessive allele for color blindness on one of her X chromosomes. The father is not color blind because he does not have the recessive allele. The sex-linked trait is represented by writing the allele on the X chromosome. Notice that the only offspring that can possibly have red-green color blindness is a male child. As a result of it being an X-linked trait, red-green color blindness is very rare in females.

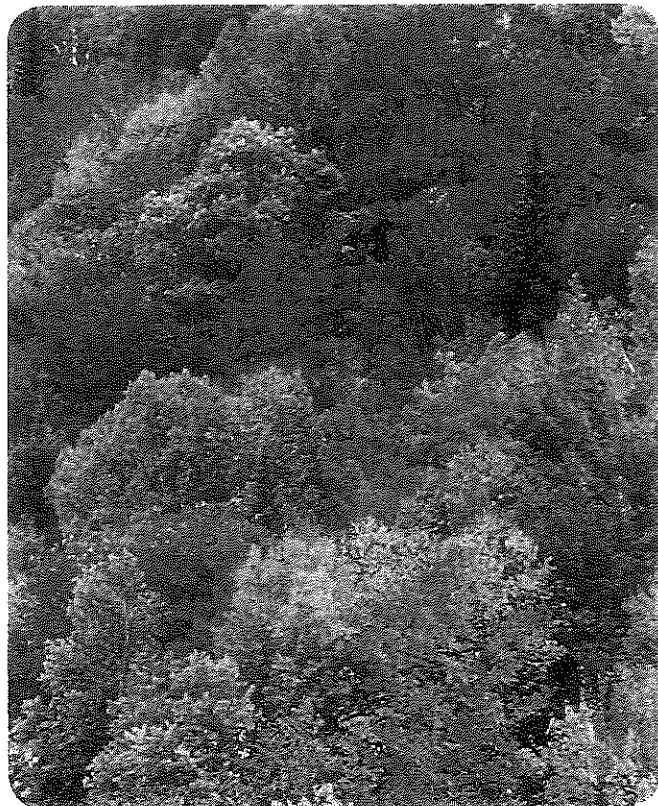

◀ **Figure 12** People with red-green color blindness view red and green as shades of gray. Explain why there are fewer females who have red-green color blindness than males.

X^B = Normal

X^b = Red-green color blind

Y = Y chromosome

	X^B	Y
X^B	$X^B X^B$	$X^B Y$
X^b	$X^B X^b$	$X^b Y$



Queen Victoria's Pedigree

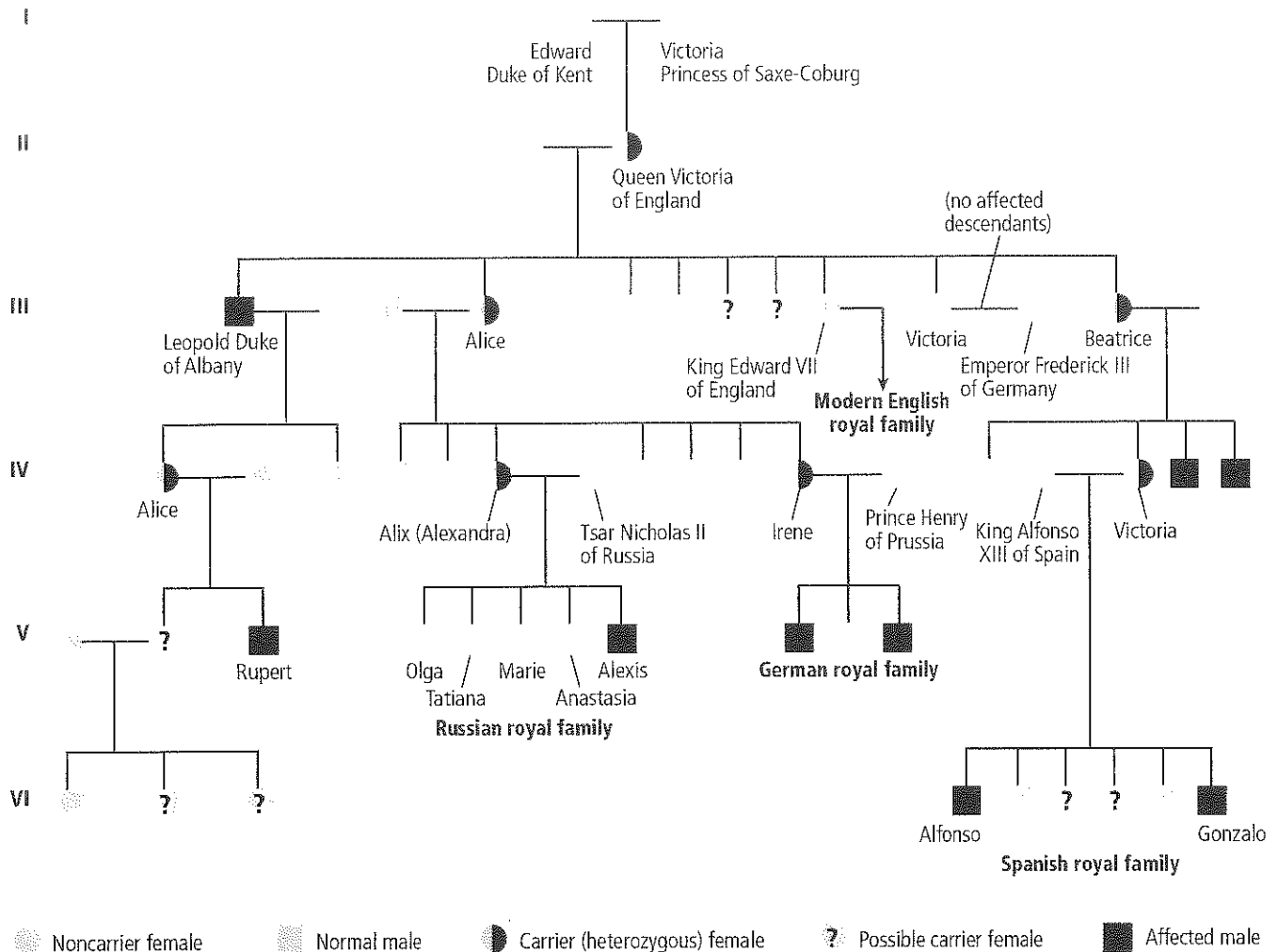

» **Figure 13** The pedigree above shows the inheritance of hemophilia in the royal families of England, Germany, Spain, and Russia, starting with the children of Queen Victoria.

Determine which of Alexandra's children inherited hemophilia.



Hemophilia Hemophilia, another recessive sex-linked disorder, is characterized by delayed clotting of the blood. Like red-green color blindness, this disorder is more common in males than in females.

A famous pedigree of hemophilia is one that arose in the family of Queen Victoria of England (1819-1901). Her son Leopold died of hemophilia, and her daughters Alice and Beatrice, as illustrated in the pedigree in **Figure 13**, were carriers for the disease. Alice and Beatrice passed on the hemophilia trait to the Russian, German, and Spanish royal families. Follow the generations in this pedigree to see how this trait was passed through Queen Victoria's family. Queen Victoria's granddaughter Alexandra, who was a carrier for this trait, married Tsar Nicholas II of Russia. Irene, another granddaughter, passed the trait on to the German royal family. Hemophilia was passed to the Spanish royal family through a third granddaughter, whose name also was Victoria.

Men with hemophilia usually died at an early age until the twentieth century when clotting factors were discovered and given to hemophiliacs. However, blood-borne viruses such as Hepatitis C and HIV were often contracted by hemophiliacs until the 1990s, when safer methods of blood transfusion were discovered.

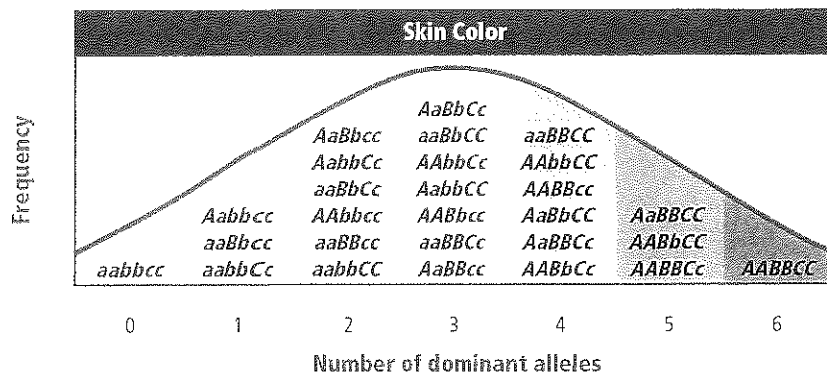

Figure 14 This graph shows possible shades of skin color from three sets of alleles, although the trait is thought to involve more than three sets of alleles. **Predict** Would more gene pairs increase or decrease the number of possible phenotypes?

Polygenic Traits

You have examined traits determined by a pair of genes. Many phenotypic traits, however, arise from the interaction of multiple pairs of genes. Such traits are called **polygenic traits**. Traits such as skin color, height, eye color, and fingerprint pattern are polygenic traits. One characteristic of polygenic traits is that, when the frequency of the number of dominant alleles is graphed, as shown in **Figure 14**, the result is a bell-shaped curve. This shows that more of the intermediate phenotypes exist than do the extreme phenotypes.

Reading Check Infer Why would a graph showing the frequency of the number of dominant alleles for polygenic traits be a bell-shaped curve?

Environmental Influences

The environment also has an effect on phenotype. For example, the tendency to develop heart disease can be inherited. However, environmental factors such as diet and exercise also can contribute to the occurrence and seriousness of the disease. Other ways in which environment influences phenotype are very familiar to you. You may not have thought of them in terms of phenotype, however. Sunlight, water, and temperature are environmental influences that commonly affect an organism's phenotype.

Sunlight and water Without enough sunlight, most flowering plants do not bear flowers. Many plants lose their leaves in response to water deficiency.

Temperature Most organisms experience phenotypic changes from extreme temperature changes. In extreme heat, for example, many plants suffer. Their leaves droop, flower buds shrivel, chlorophyll disappears, and roots stop growing. These are examples that probably do not surprise you, although you may have never thought of them as phenotypic changes. What other environmental factors affect the phenotypes of organisms? Temperature also influences the expression of genes. Notice the fur of the Siamese cat shown in **Figure 15**. The cat's tail, feet, ears, and nose are dark. These areas of the cat's body are cooler than the rest. The gene that codes for production of the color pigment in the Siamese cat's body functions only under cooler conditions. Therefore, the cooler regions are darker; and the warmer regions, where pigment production is inhibited by temperature, are lighter.

APPLYING PRACTICES

Make and Defend a Claim Based on Evidence Go to the resources tab in ConnectED to find the Applying Practices worksheet *Investigating Genetic Variation*.

Figure 15 Temperature affects the expression of color pigment in the fur of Siamese cats.

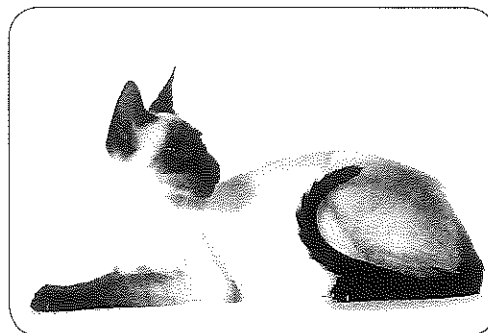

* **Figure 16** When a trait is found more often in both members of identical twins than in fraternal twins, the trait is presumed to have a significant inherited component.

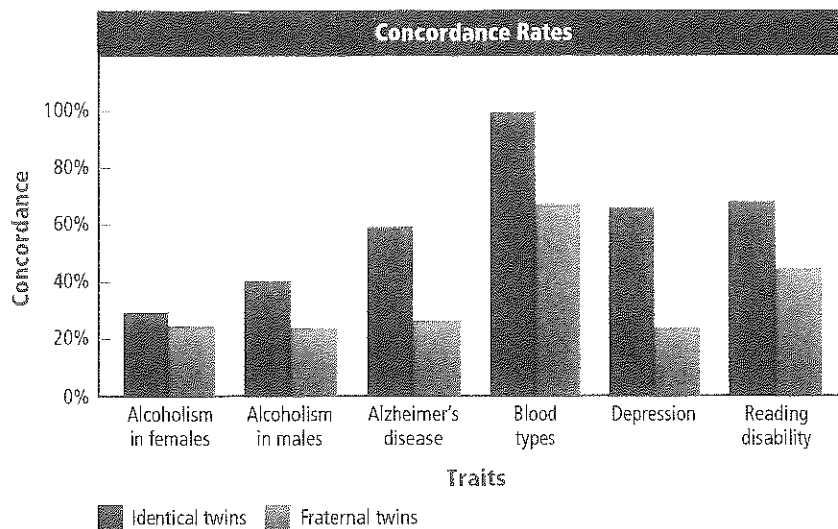

Launch Lab

Review Based on what you have read about human inheritance, how would you now answer the analysis questions?

Twin Studies

Another way to study inheritance patterns is to focus on identical twins, which helps scientists separate genetic contributions from environmental contributions. Identical twins are genetically the same. If a trait is inherited, both identical twins will have the trait. Scientists conclude that traits that appear frequently in identical twins are at least partially controlled by heredity. Also, scientists presume that traits expressed differently in identical twins are strongly influenced by environment. The percentage of twins who both express a given trait is called a concordance rate. Examine **Figure 16** for some traits and their concordance rates. A large difference between fraternal twins and identical twins shows a strong genetic influence.

Section 2 Assessment

Section Summary

- Some traits are inherited through complex inheritance patterns, such as incomplete dominance, codominance, and multiple alleles.
- Gender is determined by X and Y chromosomes. Some traits are linked to the X chromosome.
- Polygenic traits involve more than one pair of alleles.
- Both genes and environment influence an organism's phenotype.
- Studies of inheritance patterns of large families and twins give insight into complex human inheritance.

Understand Main Ideas

1. **Describe** two patterns of complex inheritance and explain how they are different from Mendelian patterns.
2. **Explain** What is epistasis, and how is it different from dominance?
3. **Determine** the genotypes of the parents if the father is blood type A, the mother is blood type B, the daughter is blood type O, one son is blood type AB, and the other son is blood type B.
4. **Analyze** how twin studies help to differentiate the effects of genetic and environmental influences.

Think Critically

5. **Evaluate** whether having sickle-cell disease would be advantageous or disadvantageous to a person living in central Africa.

MATH in Biology

6. What is the chance of producing a son with normal vision if the father is color-blind and the mother is homozygous normal for the trait? Explain.

Section 3

Reading Preview

Essential Questions

- How are karyotypes used to study genetic disorders?
- What is the role of telomeres?
- How is nondisjunction related to Down syndrome and other abnormal chromosome numbers?
- What are the benefits and risks of diagnostic fetal testing?

Review Vocabulary

mitosis: a process in the nucleus of a dividing cell, including prophase, metaphase, anaphase, and telophase

New Vocabulary

karyotype
telomere
nondisjunction

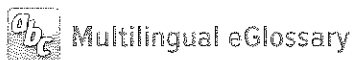

Multilingual eGlossary

Chromosomes and Human Heredity

MARK Idea Chromosomes can be studied using karyotypes.

Real-World Reading Link Have you ever lost one of the playing pieces belonging to a game? You might not have been able to play the game because the missing piece was important. Just as a misplaced game piece affects a game, a missing chromosome has a significant impact on the organism.

Karyotype Studies

The study of genetic material does not involve the study of genes alone. Scientists also study whole chromosomes by using images of chromosomes stained during metaphase. The staining bands identify or mark identical places on homologous chromosomes. During metaphase of mitosis, each chromosome has condensed greatly and consists of two sister chromatids. The pairs of homologous chromosomes are arranged in decreasing size to produce a micrograph called a **karyotype** (KER ee uh tipe). Karyotypes of a human male and a human female, each with 23 pairs of chromosomes, are shown in **Figure 17**. Notice that the 22 autosomes are matched together with one pair of nonmatching sex chromosomes.

Telomeres

Scientists have found that chromosomes end in protective caps called **telomeres**. Telomere caps consist of DNA associated with proteins. The cap serves a protective function for the structure of the chromosome. Scientists have discovered that telomeres also might be involved in both aging and cancer.

■ **Figure 17** Karyotypes arrange the pairs of homologous chromosomes from increasing to decreasing size.

Distinguish which two chromosomes are arranged separately from the other pairs.

False-Color LM Magnification: 1400x

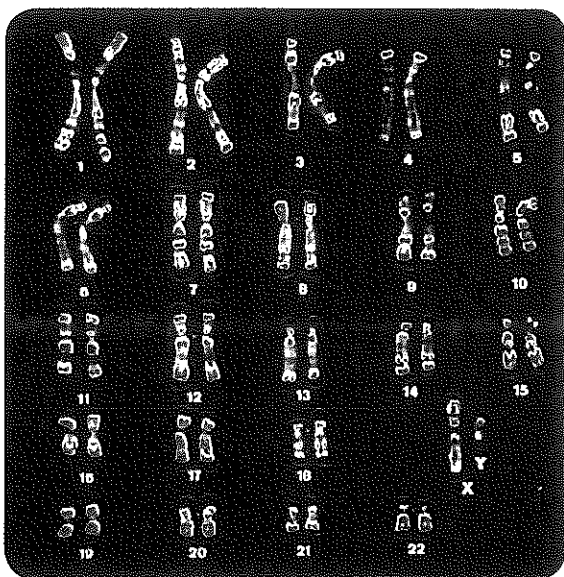

False-Color LM Magnification: 1400x

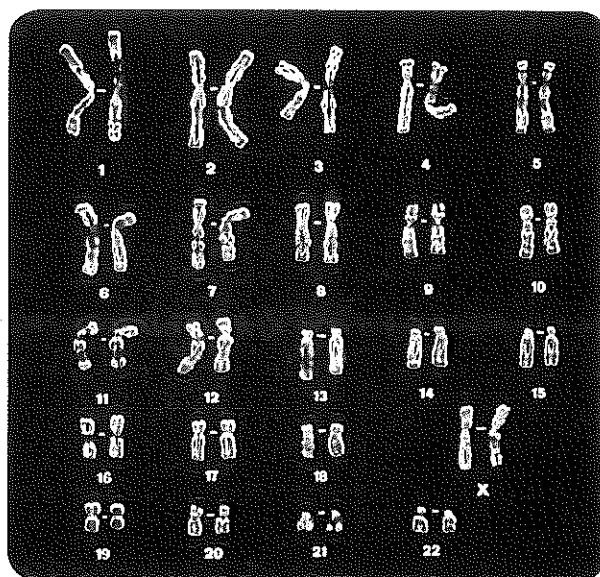

Visualizing Nondisjunction

Figure 18

Gametes with abnormal numbers of chromosomes can result from nondisjunction during meiosis. The orange chromosomes come from one parent, and the blue chromosomes come from the other parent.

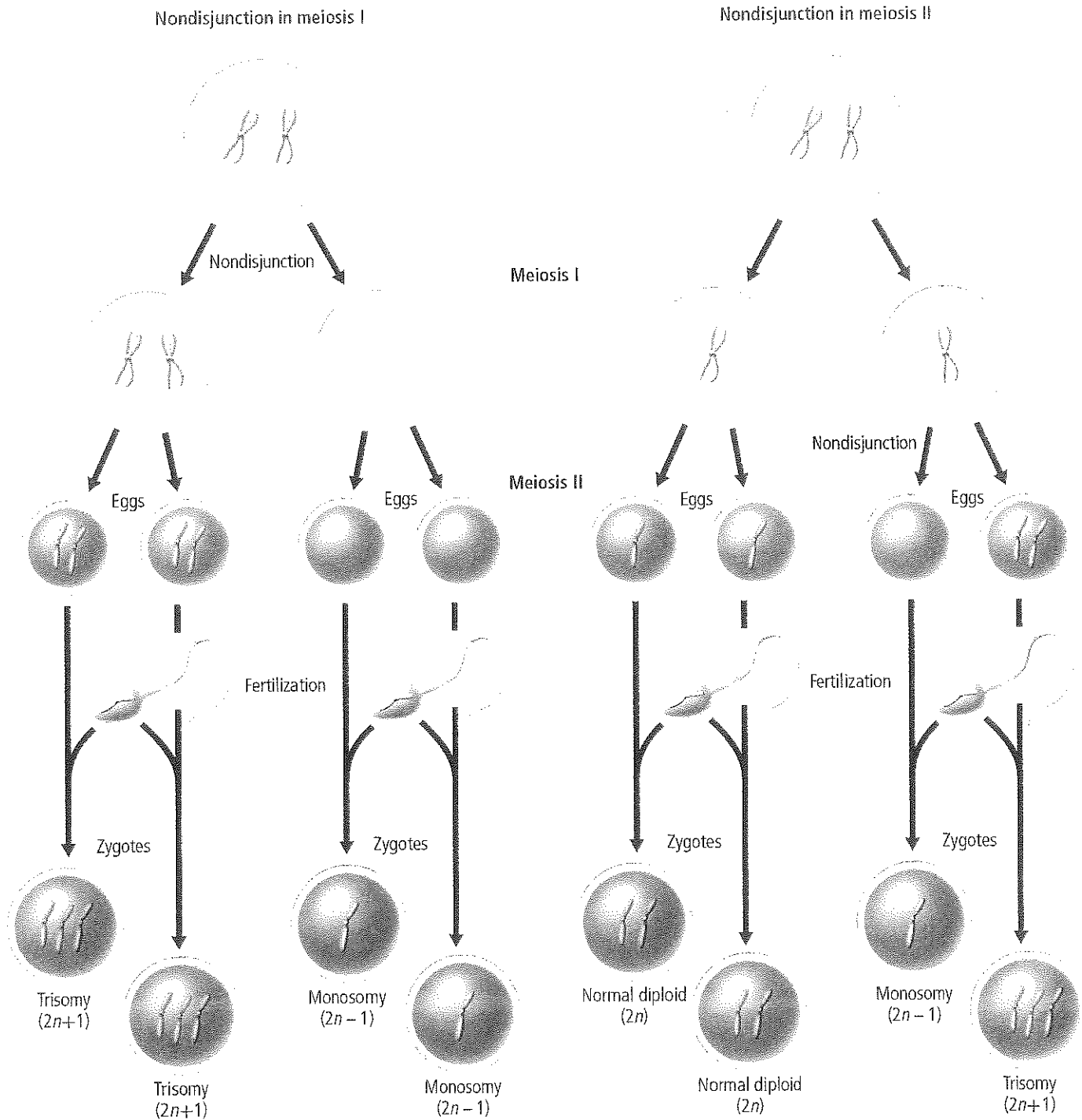

Nondisjunction

During cell division, the chromosomes separate, with one of each of the sister chromatids going to opposite poles of the cell. Therefore, each new cell has the correct number of chromosomes. Cell division during which sister chromatids fail to separate properly, which does happen occasionally, is called **nondisjunction**.

If nondisjunction occurs during meiosis I or meiosis II, as shown in **Figure 18**, the resulting gametes will not have the correct number of chromosomes. When one of these gametes fertilizes another gamete, the resulting offspring will not have the correct number of chromosomes. Notice that nondisjunction can result in extra copies of a certain chromosome or only one copy of a particular chromosome in the offspring. Having a set of three chromosomes of one kind is called trisomy (TRI so me). Having only one of a particular type of chromosome is called monosomy (MAH nuh so me). Nondisjunction can occur in any organism in which gametes are produced through meiosis. In humans, alterations of chromosome numbers are associated with serious human disorders, which are often fatal.

Down syndrome One of the earliest known human chromosomal disorders is Down syndrome. It is the result of an extra chromosome 21. Therefore, Down syndrome often is called trisomy 21. Examine the karyotype of a child with Down syndrome, shown in **Figure 19**. Notice that she has three copies of chromosome 21. The characteristics of Down syndrome include distinctive facial features, as shown in **Figure 19**, short stature, heart defects, and mental disability. The frequency of children born with Down syndrome in the United States is approximately one out of 800. The frequency of Down syndrome increases with the age of the mother. Studies have shown that the risk of having a child with Down syndrome is about six percent in mothers who are 45 and older.

Research Scientist Research scientists know and research a particular field of science, such as genetic disorders. Most research scientists begin their work in their undergraduate studies and continue on to a Master's degree or Ph.D.

✳ **Figure 19** A person with Down syndrome has distinctive features and will have a karyotype that shows three copies of chromosome number 21.

False-Color LM Magnification: 1400×

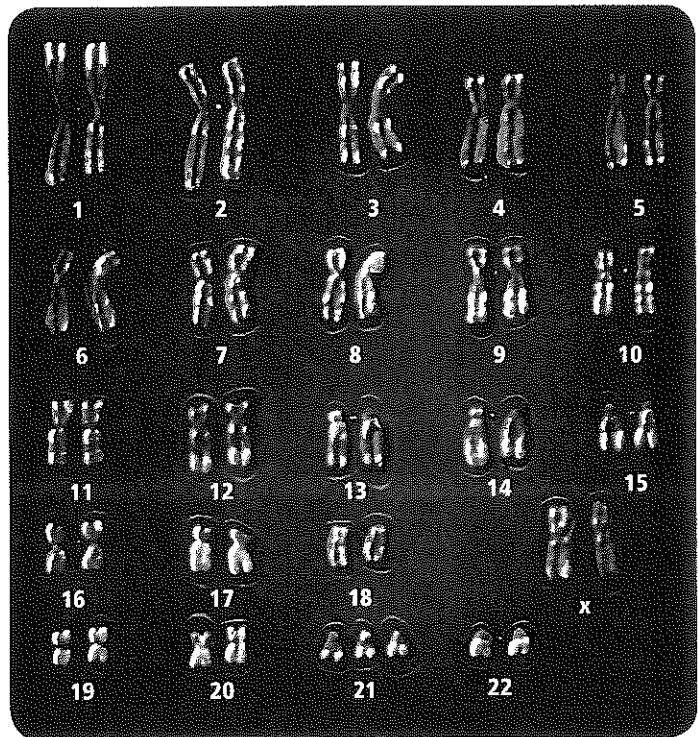

Table 4**Nondisjunction in Sex Chromosomes**

Interactive Table

Genotype	XX	XO	XXX	XY	XXY	XYY	OY
Example							
Phenotype	Normal female	Female with Turner's syndrome	Nearly normal female	Normal male	Male with Klinefelter's syndrome	Normal or nearly normal male	Results in death

Sex chromosomes Nondisjunction occurs in both autosomes and sex chromosomes. Some of the results of nondisjunction in human sex chromosomes are listed in **Table 4**. Note that an individual with Turner's syndrome has only one sex chromosome. This condition results from fertilization with a gamete that had no sex chromosome.

Fetal Testing

Couples who suspect they might be carriers for certain genetic disorders might want to have a fetal test performed. Older couples also might wish to know the chromosomal status of their developing baby, called the fetus. Various types of tests for observing both the mother and the baby are available.

Mini Lab 2

MiniLab

Explore the Methods of the Geneticist

How do geneticists learn about human heredity? Traditional methods used to investigate the genetics of plants, animals, and microbes are not suitable or possible to use on humans. A pedigree is one useful tool for investigating human inheritance. In this lab, you will explore yet another tool of the geneticist—population sampling.

Procedure   

1. Read and complete the lab safety form.
2. Construct a data table as instructed by your teacher.
3. Survey your group for the hitchhiker's thumb trait.
4. Survey your group for other traits determined by your teacher.
5. Compile the class data, and analyze the traits that you investigated in the survey population. Determine which of the traits are dominant and which are recessive.

Analysis

1. **Interpret Data** What numerical clue did you look for to determine whether each trait surveyed was dominant or recessive?
2. **Think Critically** How could you check to see if you correctly identified dominant and recessive traits? Explain why you might have misidentified a trait.



Table 5**Fetal Tests**

Interactive Table

Test	Benefit	Risk
Amniocentesis	<ul style="list-style-type: none"> • Diagnosis of chromosome abnormalities • Diagnosis of other defects 	<ul style="list-style-type: none"> • Discomfort for expectant mother • Slight risk of infection • Risk of miscarriage
Chorionic villus sampling	<ul style="list-style-type: none"> • Diagnosis of chromosome abnormality • Diagnosis of certain genetic defects 	<ul style="list-style-type: none"> • Risk of miscarriage • Risk of infection • Risk of newborn limb defects
Fetal blood sampling	<ul style="list-style-type: none"> • Diagnosis of genetic or chromosome abnormality • Checks for fetal blood problems and oxygen levels • Medications can be given to the fetus before birth 	<ul style="list-style-type: none"> • Risk of bleeding from sample site • Risk of infection • Amniotic fluid might leak • Risk of fetal death

Connection to

Many fetal tests can provide important information to the parents and the physician. **Table 5** describes the risks and benefits of some of the fetal tests that are available. Physicians must consider many factors when advising parents about such examinations. At least a small degree of risk is possible in any test or procedure. A physician would not want to advise tests that would endanger the mother or the fetus; therefore, when considering whether to recommend fetal testing, a physician would need to consider previous health problems of the mother and also the health of the fetus. If the physician and parents determine that any fetal test is needed, the health of both the mother and the fetus is closely monitored throughout the testing.

Section 3 Assessment

Section Summary

- Karyotypes are micrographs of chromosomes.
- Chromosomes terminate in a cap called a telomere.
- Nondisjunction results in gametes with an abnormal number of chromosomes.
- Down syndrome is a result of nondisjunction.
- Tests for assessing the possibility of genetic and chromosomal disorders are available.

Understand Main Ideas

1. **MARK Idea** Explain how a scientist might use a karyotype to study genetic disorders.
2. **Summarize** the role of telomeres.
3. **Illustrate** Draw a sketch to show how nondisjunction occurs during meiosis.
4. **Analyze** Why might missing sections of the X or Y chromosome be a bigger problem in males than deletions would be in one of the X chromosomes in females?

Think Critically

5. **Create** a karyotype of a female organism in which $2n = 8$, showing trisomy of chromosome 3.
6. **Discuss** the benefits and risks of fetal testing.

WRITING in Biology

7. Conduct research on the consequences of nondisjunction other than trisomy 21. Write a paragraph about your findings.



In the Field

Career: Genetic Counselor Genetic Testing and Support

Have you ever looked at your family tree? Do you know of any disorders or diseases that “run” in families? Genetic counselors specialize in uncovering, interpreting, and explaining this information.

Genetic counselors Genetic counselors apply their knowledge of genetics to provide information and support to people who are affected by genetic disorders. They specialize in evaluating genetic tests and indicating prevention, monitoring, and treatment options related to specific genetic conditions. Genetic counselors are also trained to deal with the emotional aspects associated with learning the results of a genetic test. They serve as patient advocates, referring individuals to community or state support services.

What does genetic testing involve? Tests are done to determine if any abnormalities are present in a particular gene or chromosome. Testing usually involves a sample of blood or tissue. In the case of prenatal genetic testing, a sample of amniotic fluid or tissue from around a fetus is taken.

It can be helpful to provide medical details about other people in your family, usually going back to your grandparents’ generation, prior to meeting with a genetic counselor. Sometimes a family history gives doctors enough information to diagnose a genetic condition.

Who gets genetic testing? Sometimes a doctor recommends genetic testing. Other times, individuals seek it for themselves.



A genetic test can determine if any abnormalities are present in a particular gene or chromosome.

Possible reasons for genetic testing include:

- a family history of genetic disorders;
- an unusual occurrence of certain types of cancer;
- having a child with learning difficulties or health problems, which might have a genetic cause;
- couples planning pregnancy who wish to determine if their child is at risk for a genetic condition.

Several hundred genetic tests are currently in use, with more being developed. While a doctor or health care specialist can order a genetic test, they often refer patients to genetic counselors who have received special training to interpret such tests, suggest available options, and provide supportive counseling.

WRITING in Biology

Debate Use the Skillbuilder Handbook to organize a debate about the use and potential implications of genetic testing. Write a summary of your notes and your argument before participating in the debate.

David Buffington/Photodisc/Getty Images



BIOLAB

WHAT'S IN A FACE? INVESTIGATE INHERITED HUMAN FACIAL CHARACTERISTICS

Background: Most people know that they inherit their hair color and their eye color from their parents. However, there are many other head and facial traits that humans inherit. In this lab, you will investigate a number of different inherited facial structures that combine to compose a human face.

Question: *What structures that comprise the human face are actually determined genetically?*

Materials

coins, 2 per team: heads=dominant trait,
tails=recessive trait
table of inherited human facial characteristics provided by the teacher

Procedure

1. Read and complete the lab safety form.
2. Partner with a classmate.
3. One member of the team will represent the father, and one member will represent the mother. Decide which partner will represent the father and who will represent the mother.
4. Have the person representing the father flip a coin. If the coin lands *heads* facing up, the offspring is a female; if the coin lands *tails* facing up, the offspring is a male. Record the gender of the offspring.
5. Flip your coin at the same time as your partner. Flip the coins only once for each trait.
6. Continue to flip coins for each trait shown in the table. After each coin flip, record the trait of your offspring by placing a check in the appropriate box in the table.
7. Once the traits are determined, draw the offspring's facial features, give him or her a name, and be prepared to introduce the offspring to the rest of the class.

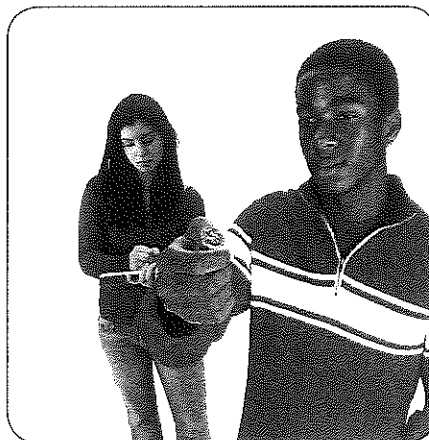

Analyze and Conclude

1. **Think Critically** Why did the partner representing the father flip the coin initially to determine the gender of the offspring?
2. **Calculate** What percent chance was there of producing male offspring? Female offspring? Explain.
3. **Recognize Cause and Effect** What are the possible genotypes of parents of the following three children: a boy with straight hair (hh), a daughter with wavy hair (Hh), and a son with curly hair (HH)?
4. **Observe and Infer** Which traits show codominance?
5. **Analyze and Conclude** Would you expect other student pairs in the class to have offspring exactly like yours? Explain.

WRITING in Biology

Research Imagine that you write a science column for a large newspaper. A reader has written to you asking for a job description for a genetic counselor. Research this question; then write a short newspaper column answering the question.



Chapter 11 Study Guide

THEME FOCUS Cause and Effect Complex forms of inheritance, such as multiple alleles and codominance in the ABO blood group, result in a range of characteristics that contribute to the diversity and success of a species.

Big Idea Human inheritance does not always follow Mendel's laws.

Section 1 Basic Patterns of Human Inheritance

carrier (p. 296)
pedigree (p. 299)

Big Idea The inheritance of a trait over several generations can be shown in a pedigree.

- Genetic disorders can be caused by dominant or recessive alleles.
- Cystic fibrosis is a genetic disorder that affects mucus and sweat secretions.
- Individuals with albinism do not have melanin in their skin, hair, and eyes.
- Huntington's disease affects the nervous system.
- Achondroplasia sometimes is called dwarfism.
- Pedigrees are used to study human inheritance patterns.

Section 2 Complex Patterns of Inheritance

incomplete dominance (p. 302)
codominance (p. 302)
multiple alleles (p. 304)
epistasis (p. 305)
sex chromosome (p. 305)
autosome (p. 305)
sex-linked trait (p. 307)
polygenic trait (p. 309)

Big Idea Complex inheritance of traits does not follow inheritance patterns described by Mendel.

- Some traits are inherited through complex inheritance patterns, such as incomplete dominance, codominance, and multiple alleles.
- Gender is determined by X and Y chromosomes. Some traits are linked to the X chromosome.
- Polygenic traits involve more than one pair of alleles.
- Both genes and environment influence an organism's phenotype.
- Studies of inheritance patterns of large families and twins give insight into complex human inheritance.

Section 3 Chromosomes and Human Heredity

karyotype (p. 311)
telomere (p. 311)
nondisjunction (p. 313)

Big Idea Chromosomes can be studied using karyotypes.

- Karyotypes are micrographs of chromosomes.
- Chromosomes terminate in a cap called a telomere.
- Nondisjunction results in gametes with an abnormal number of chromosomes.
- Down syndrome is a result of nondisjunction.
- Tests for assessing the possibility of genetic and chromosomal disorders are available.

Chapter 11 Assessment

Section 1

Vocabulary Review

Use what you know about the vocabulary terms from the Study Guide page to answer the questions.

1. Which term describes a person who is heterozygous for a recessive disorder?
2. How is the inheritance pattern between parents and offspring represented diagrammatically?

Understand Main Ideas

3. Which condition is inherited as a dominant allele?
A. albinism
B. cystic fibrosis
C. Tay-Sachs disease
D. Huntington's disease
4. Which is not a characteristic of a person with cystic fibrosis?
A. chloride channel defect
B. digestive problems
C. lack of skin pigment
D. recurrent lung infections

Use the diagram below to answer questions 5 and 6.

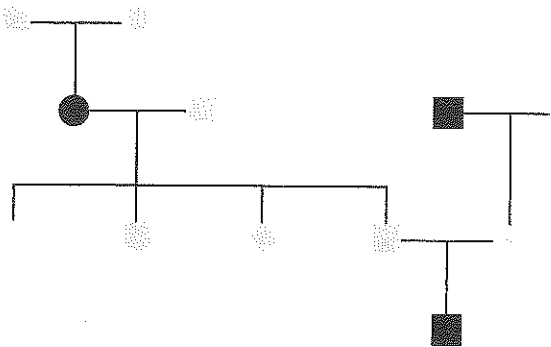

5. Which disorder could not follow the inheritance pattern shown?
A. cystic fibrosis
B. albinism
C. Tay-Sachs disease
D. Huntington's disease
6. How many affected males and females are in the pedigree?
A. 1 male, 2 females C. 1 male, 1 female
B. 2 males, 1 female D. 2 males, 2 females

Constructed Response

Use the photo below to answer question 7.

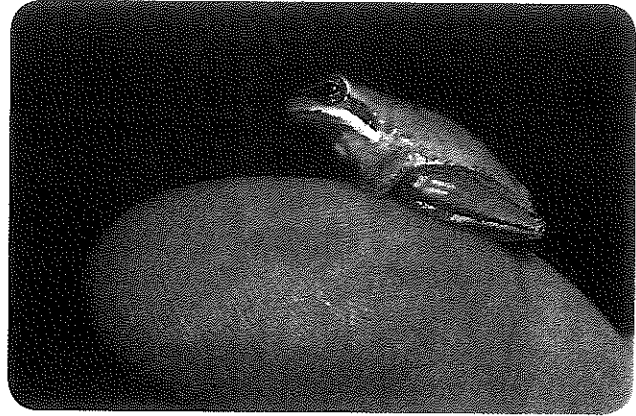

7. **Open Ended** Imagine that all animals have the same genetic disorders that humans have. What is the biological name of the genetic disorder that this dwarf tree frog would have? Describe the inheritance pattern of the genetic disorder.
8. **Short Answer** Predict the genotypes of the children of a father with Huntington's disease and an unaffected mother.

Think Critically

9. **Draw a conclusion** about the relationship of chloride ions to the excessively thick mucus in a patient suffering from cystic fibrosis.

Section 2

Vocabulary Review

Replace each underlined word with the correct vocabulary term from the Study Guide page.

10. Codominance is an inheritance pattern in which the heterozygous genotype results in an intermediate phenotype between the dominant and recessive phenotype.
11. A characteristic that has more than one pair of possible traits is said to be a(n) epistasis.
12. Genes found on the sex chromosomes are associated with multiple alleles.



Understand Main Ideas

13. What determines gender in humans?
 - A. the X and Y chromosomes
 - B. chromosome 21
 - C. codominance
 - D. epistasis
14. **Multiple Choice** Which two terms best describe the inheritance of human blood types?
 - A. incomplete dominance and codominance
 - B. codominance and multiple alleles
 - C. incomplete dominance and multiple alleles
 - D. codominance and epistasis

Use the photos below to answer question 15.

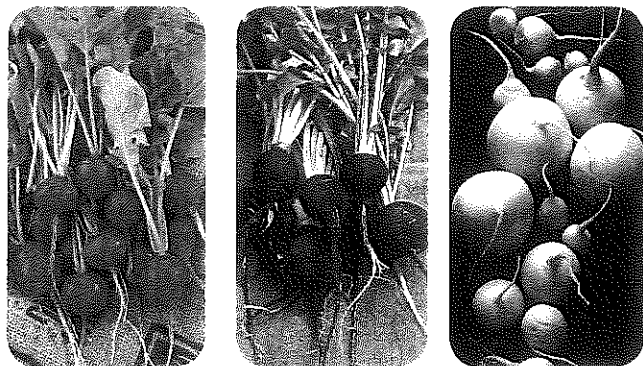

15. **THEME FOCUS Cause and Effect** In radishes, color is controlled by incomplete dominance. The figure above shows the phenotype for each color. What phenotypic ratios would you expect from crossing two heterozygous plants?
 - A. 2: 2 red: white
 - B. 1: 1: 1 red: purple: white
 - C. 1: 2: 1 red: purple: white
 - D. 3: 1 red: white

Constructed Response

16. **Short Answer** How does epistasis explain the differences in coat color in Labrador retrievers?
17. **Short Answer** Explain whether a male could be heterozygous for red-green color blindness.
18. **Short Answer** What types of phenotypes would one look for if a phenotype were a result of polygenic inheritance?

Think Critically

19. **Evaluate** why it might be difficult to perform genetic analysis in humans.

20. **Summarize** the meaning of the following information regarding trait inheritance: For a certain trait, identical twins have a concordance rate of 54 percent and fraternal twins have a rate of less than five percent.

Section 3

Vocabulary Review

Identify the vocabulary term from the Study Guide page described by each definition.

21. the protective ends of the chromosome
22. an error that occurs during cell division
23. a micrograph of stained chromosomes

Understand Main Ideas

24. **Multiple Choice** What could explain a human karyotype showing 47 chromosomes?
 - A. monosomy
 - B. trisomy
 - C. codominance
 - D. dominant traits
25. Why does nondisjunction occur?
 - A. Cytokinesis does not occur properly.
 - B. The nucleoli do not disappear.
 - C. The sister chromatids do not separate.
 - D. The chromosomes do not condense properly.

Use the photo below to answer question 26.

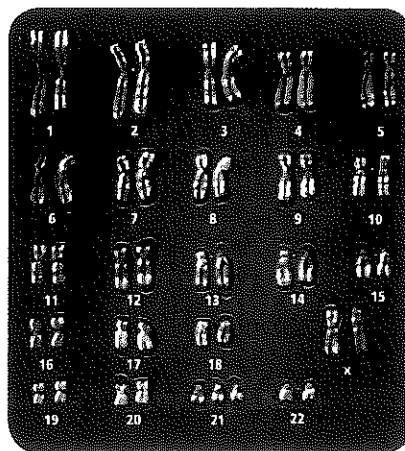

26. What disorder can be identified in the karyotype?
 - A. Turner's syndrome
 - B. Klinefelter's syndrome
 - C. Down syndrome
 - D. The karyotype shows no disorder.



27. Which statement concerning telomeres is not true?
- They are found on the ends of chromosomes.
 - They consist of DNA and sugars.
 - They protect chromosomes.
 - They are involved with aging.

Constructed Response

Use the photo below to answer question 28.

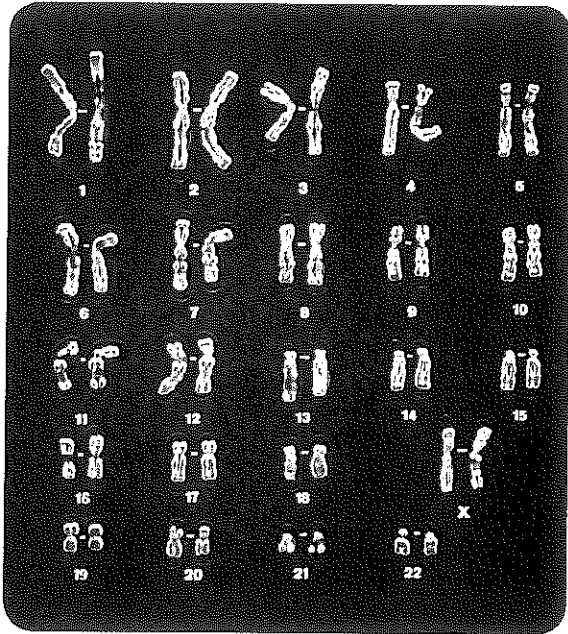

28. **Short Answer** Describe a fetal test that results in the karyotype shown above.
29. **Short Answer** What characteristics are associated with Down syndrome?
30. **Open Ended** Most cases of trisomy and monosomy in humans are fatal. Why might this be?

Think Critically

31. **Hypothesize** why chromosomes need telomeres.
32. **Explain** why a girl who has Turner's syndrome has red-green color blindness even though both of her parents have normal vision.
33. **Illustrate** what might have occurred to result in an extra chromosome in the following example: A technician is constructing a karyotype from male fetal cells. The technician discovers that the cells have one extra X chromosome.

Summative Assessment

34. **Big Idea** Give a specific example of an inheritable trait that does not follow Mendel's laws of inheritance. Apply Mendel's laws to that trait, and infer how the resulting genotypes and phenotypes would be different from what actually exists.
35. Describe how hemophilia is inherited.
36. Describe the cause of Down syndrome.
37. **Writing in Biology** Write a scenario for one of the genetic disorders described in **Table 2**. Then create a pedigree illustrating the scenario.

DB Document-Based Questions

Answer the questions below concerning the effect of environment on phenotype.

Data obtained from: Harnly, M.H. 1936. Genetics. *Journal of Experimental Zoology* 56: 363-379.

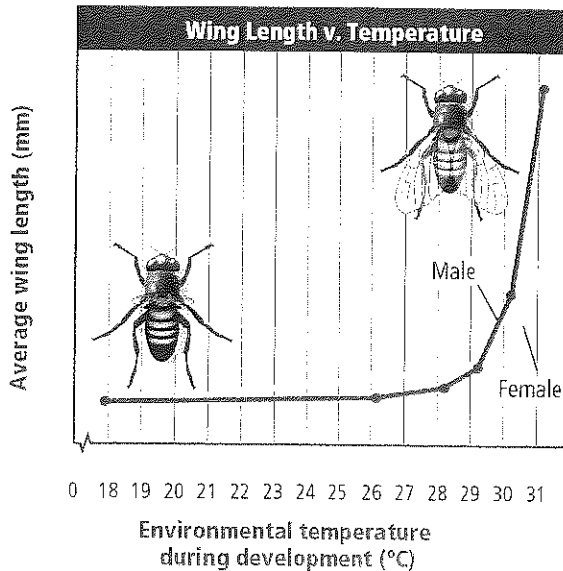

38. At which temperature is wing length the greatest?
39. Is male or female wing length more influenced by temperature? Explain.
40. What is the relationship between temperature and wing length for all flies?



Standardized Test Practice

Cumulative

Multiple Choice

- Which is affected when a cell has a low surface-area-to-volume ratio?
 - the ability of oxygen to diffuse into the cell
 - the amount of energy produced in the cell
 - the diffusion of proteins through the cells
 - the rate of protein synthesis in the cell

Use the diagram below to answer questions 2 to 4.

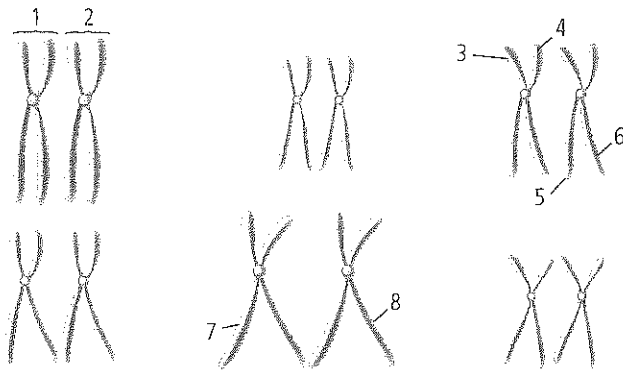

- Which labeled structures represent a homologous pair?
 - 1 and 2
 - 3 and 4
 - 3 and 6
 - 7 and 8
- Which parts of the chromosomes shown could appear together in a gamete of this organism?
 - 1 and 2
 - 3 and 6
 - 3 and 7
 - 5 and 6
- If the diagram shows all the chromosomes from a body cell, how many chromosomes would be in a gamete of this organism at the end of meiosis I?
 - 3
 - 6
 - 9
 - 12
- Which represents a polyploid organism?
 - $1/2 n$
 - $1 \frac{1}{2} n$
 - $2 n$
 - $3 n$

Use the pedigree below to answer questions 6 and 7.

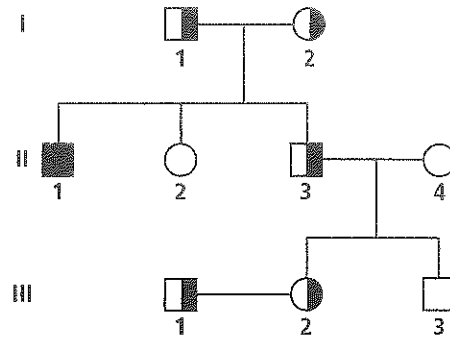

- Which person could develop symptoms of the disease that is tracked in the pedigree?
 - I1
 - II1
 - II2
 - III2
- According to the pedigree, who is a carrier and cannot have children with the disease?
 - I1
 - II1
 - II3
 - III1
- Which condition would trigger mitosis?
 - Cells touch each other.
 - Cyclin builds up.
 - Environmental conditions are poor.
 - Growth factors are absent.
- Shivering when you are cold raises your body temperature. This is an example of which characteristic of life?
 - Your body adapts over time.
 - Your body grows and develops.
 - Your body has one or more cells.
 - Your body maintains homeostasis.



Short Answer

- In pea plants, yellow seed color is the dominant trait, and green seed color is the recessive trait. Use a Punnett square to show the results of a cross between a heterozygous yellow-seed plant and a green-seed plant.
- Based on your Punnett square from question 10, what percentage of the offspring would have a homozygous genotype? Explain your answer.
- Because Huntington's disease is a dominant genetic disorder, it might seem that it would be selected out of a population naturally. Write a hypothesis that states why the disease continues to occur.
- Explain how a cancerous tumor results from a disruption of the cell cycle.
- Write, in order, the steps that must occur for cell division to result in an organism with trisomy.
- Which function in metabolism is performed by both the thylakoid membrane and the mitochondrial membrane? Give a reason why this function might or might not be important.
- Suppose two parents have a mild form of a genetic disease, but their child is born with a very severe form of the same disease. What kind of inheritance pattern took place for this disease?
- Describe an example of each of the following: species diversity, genetic diversity, and ecosystem diversity.

Extended Response

Use the diagram below to answer question 18.

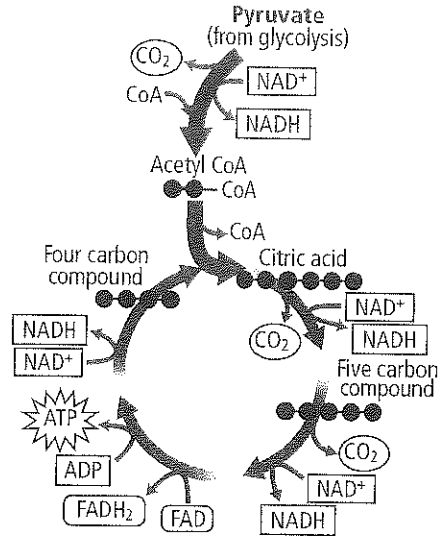

- Identify the cycle in the figure and summarize the steps of the cycle.
- Describe the function of microtubules, and predict what might happen if cells did NOT have microtubules.

Essay Question

The type of pea plants that Mendel investigated had either purple flowers or white flowers. One flower-color trait is dominant, and the other is recessive.

Using the information in the paragraph above, answer the following question in essay format.

- Explain what crosses Mendel would have performed to determine which color is the dominant trait.

NEED EXTRA HELP?

If You Missed Question . . .

1	2	3	4	5	6	7	8	9	10	11	12	13	14	15	16	17	18	19	20
---	---	---	---	---	---	---	---	---	----	----	----	----	----	----	----	----	----	----	----

Review Section . . .

9.1	10.1	10.1	10.1	10.1	11.1	11.1	9.2	1.1	10.2	10.2	11.1	9.3	11.3	8.2, 8.3	11.2	2.2	8.3	7.3	10.2
-----	------	------	------	------	------	------	-----	-----	------	------	------	-----	------	----------	------	-----	-----	-----	------

